

## Starter Bracket

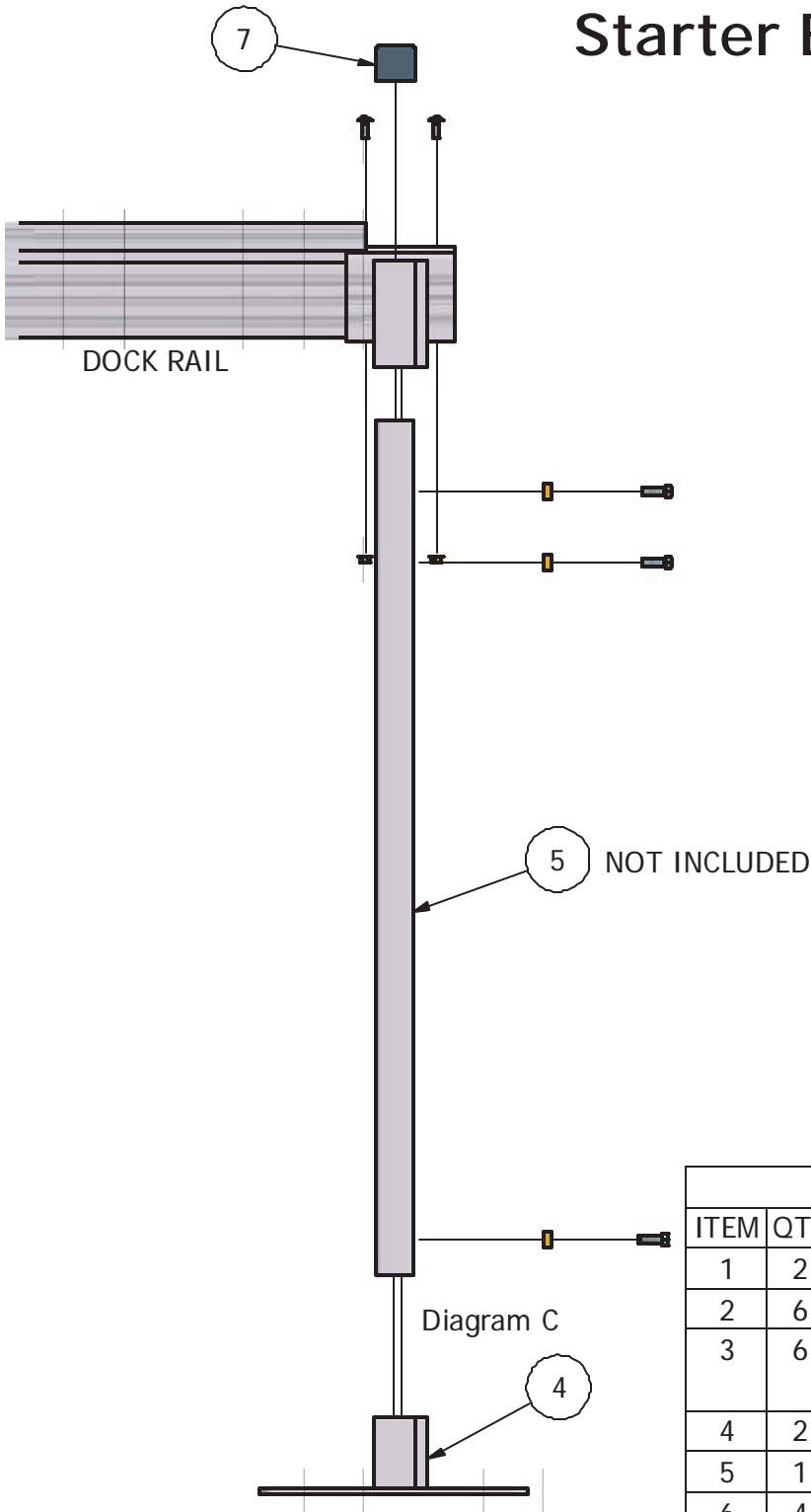

PARTS LIST			
ITEM	QTY	PART NUMBER	DESCRIPTION
1	2	VM-016	START BRKT SCKET
2	6	HD-00058	1/2 SQ NUT BRASS VSF
3	6	HD-00060	1/2 X 1 1/4 SQ HEAD BOLT S/S
4	2	VOY001-FOOTPAD	DETACHABLE FOOTPAD
5	1	NOT INCLUDED	DOCK LEG
6	4	HD-00059	3/8 X 1 SS CAR
7	2	HD-00081	2X2 CAP
8	4	HD-00056	3/8 FLANGE BRASS NUT

6

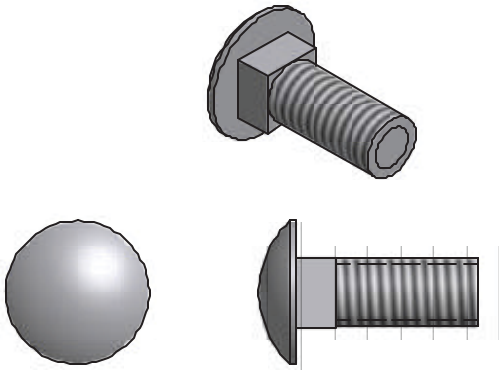

3/8 X 1 S.S. CARRIDGE BOLT (4 REQ'D)

9

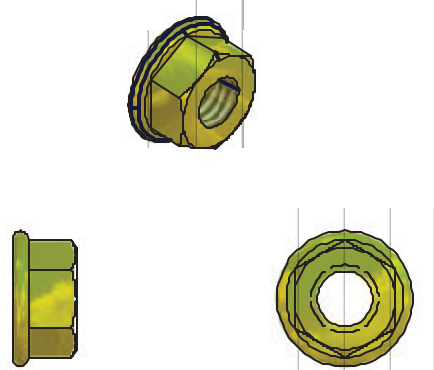

3/8 FLANGE NUT (4 REQ'D)

3

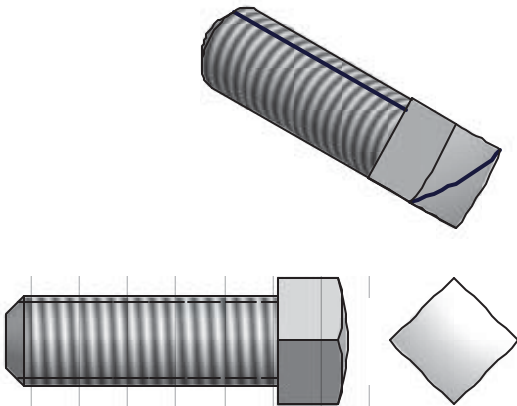

1/2 X 1 1/4 SQ. HEAD BOLT (6 REQ'D)

2

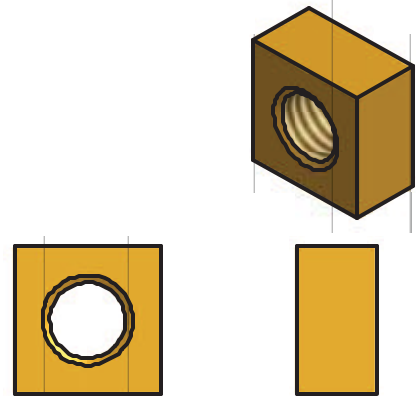

1/2 SQ. NUT BRASS (6 REQ'D)

7

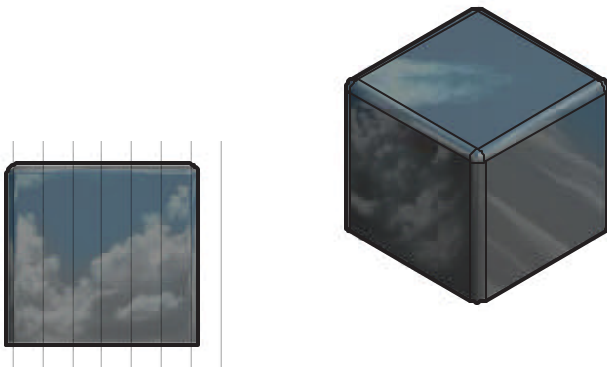

2 X 2 CAP (2 REQ'D)

**To insure your safety while assembling your Voyager product:**

- Fully read and understand the assembly instructions
- Do not assemble this product if items are missing or damaged
- Wear protective gloves, clothing and eye wear when assembling this product

**Installation procedure**

The following tools will be needed: 1/2" wrench, 9/16" wrench, tape measure, level

1. Insert head of 2- carriage bolts into raceway on the underside of dock rail and slide to desired location on dock. **Per diagram A.**
2. Put square nuts into bracket and start bolts in nut to keep in place. **Per diagram B.**
3. Take foot pad and slide square nut into place and start bolt to keep in place. **Per diagram C.**
4. Slide bracket into dock rail, put carriage bolts into bracket and attach flange nuts. **Per diagram D.**
5. Take 9/16" wrench and tighten flange nuts.
6. Slide dock leg into dock bracket\*\*, put foot pad onto leg and tighten set bolt with 1/2" wrench.
7. Put leg to desired height using tape measure or level and tighten set bolts with 1/2" wrench.
8. Install cap onto top of dock leg.
9. Repeat steps 1-8 for second bracket.

**\*\*dock leg not supplied in kit, sold separate**

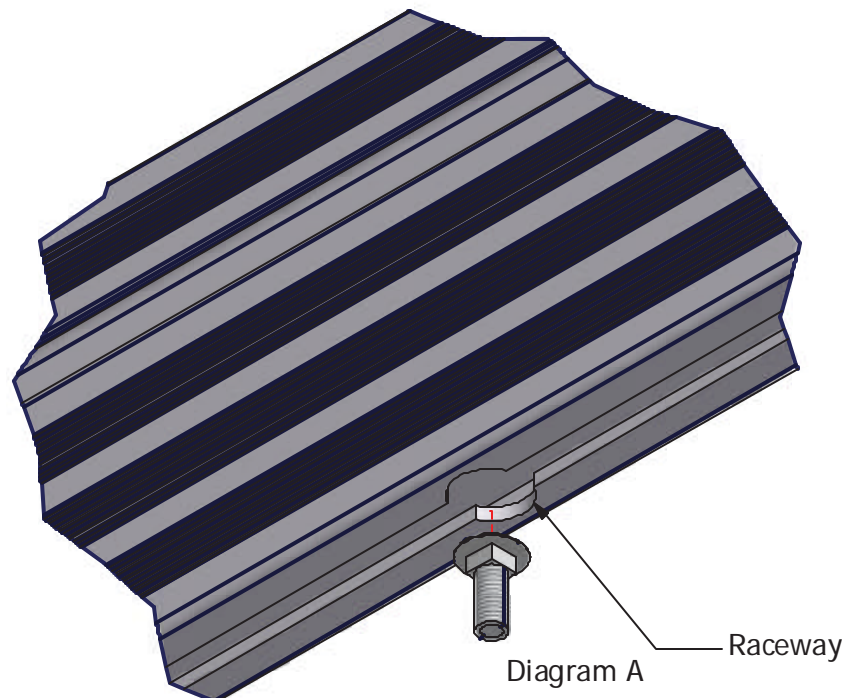

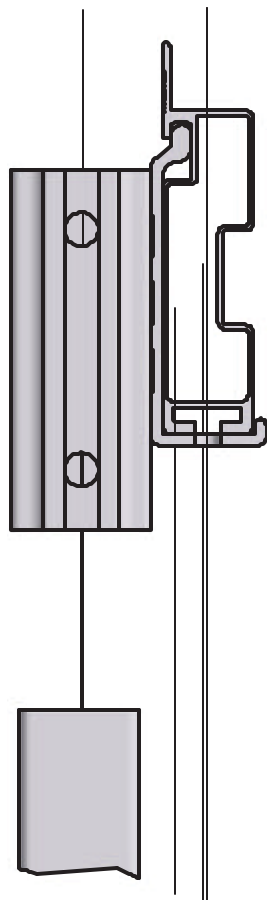

Diagram D

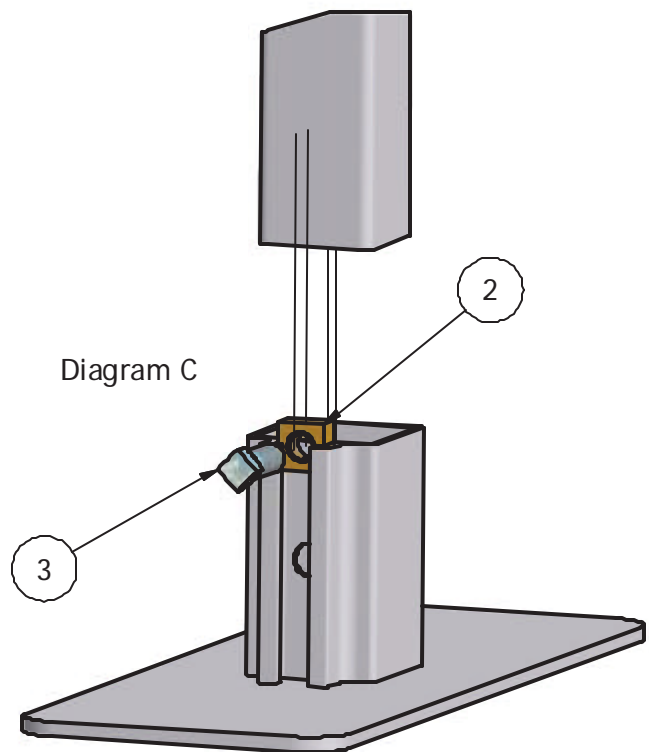

Diagram C

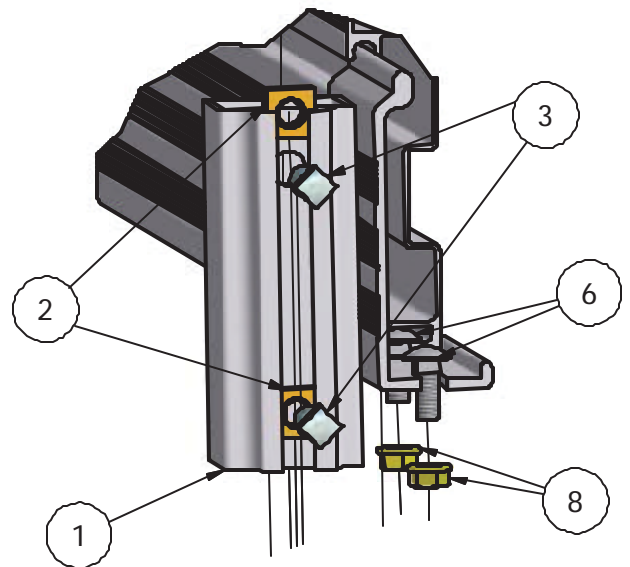

Diagram B