



Dual Wheel



PARTS LIST			
ITEM	QTY	PART NUMBER	DESCRIPTION
1	1	VM-149-01	DUAL WHEEL BRACKET
2	2	HD-00053	3 INCH AXLE WASHER
3	1	HD-00075	5/16 X 3 UNC SS
4	1	HD-00078	5/16 X .688 SS FLAT WASHER
5	1	HD-00079	5/16 SS LOCK WASHER
6	1	HD-00080	5/16 UNC SS NUT
7	2	HD-00126	3/8 X 3 1/2 HEX BOLTS S/S
8	2	HD-00056	3/8 FLANGE NUT BRASS

3

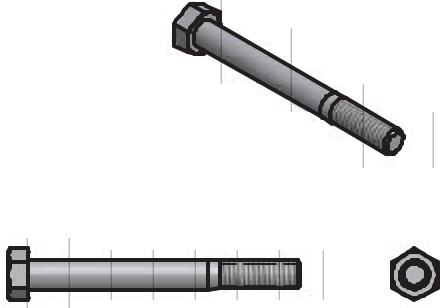

5/16-18 X 3" HCS BOLTS S/S (1 REQ'D)

4

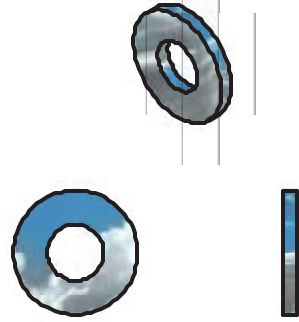

5/16 WASHERS S/S (1 REQ'D)

5

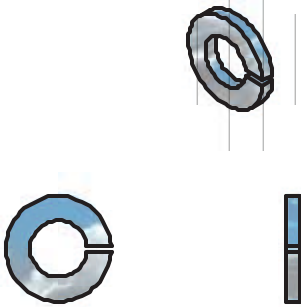

5/16 LOCK WASHERS S/S (1 REQ'D)

6

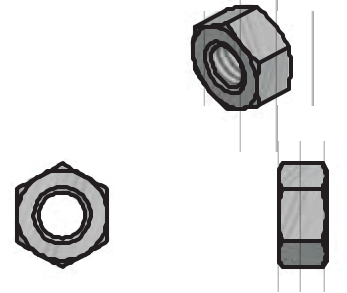

5/16 NUTS S/S (1 REQ'D)

8

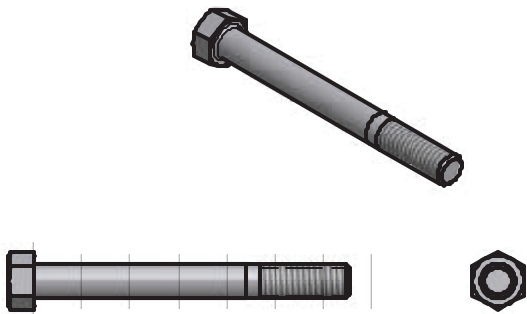

3/8 X 3 1/2 HEX BOLTS S/S (2 REQ'D)

9

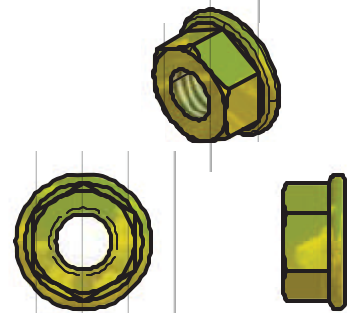

3/8 FLANGE NUT BRASS (2 REQ'D)

2

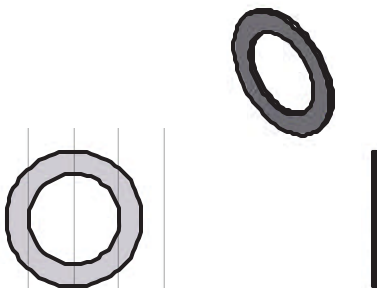

3" ALUMINUM WASHERS (2 REQ'D)

1

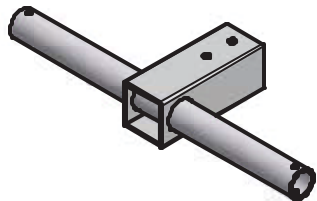

DUAL WHEEL BRACKET (1 REQ'D)

To insure you safety while assembling your Voyager product:

- Fully read and understand the assembly instructions
- Do not assemble this product if items are missing or damaged
- Wear protective gloves, clothing and eye wear when assembling this product

❖ *Note: You may need assistance when turning dock over and also when installing dock into the water.*

Installation procedure

The following tools will be needed: 2- ½" wrenches, 2- 9/16" wrenches, 15/16" socket and ratchet or wrench, drill with 7/16" drill bit, cut off saw, square, tape measure, level and marking utensil.

1. If screw leg is already attached to dock (**if not go to step 2**): raise end of dock up, block up off the ground securely so wheels are off the ground. Remove tires and washers (these parts will be used again in step 8).
2. Mark end of tube close to axle with pencil/pen. Take square and mark around the leg. (*Take tape measure, measure up from end of leg to mark and write dimension down for use on cutting second leg off*). **Per diagram A.**
3. Take saw and cut end of leg off. **Per diagram B.**
4. Slide new bracket onto leg as far as it will go. **Per diagram C.**
5. Using holes in bracket as a guide take drill and drill bit and drill into leg. Drill first hole and then put 3/8" x 3" bolt in with flange nut in, before drilling second hole to help keep bracket in place. **Per diagram C.**
6. After drilling second hole attach bracket with second-3/8 x 3 ½" bolt and 3/8" flange nut. **Per diagram C.**
7. Take 2- 9/16" wrenches and tighten bolts.
8. Slide 1- 3" washer on to axle tube, slide on poly tire and put on 1-3" washer onto axle (using hardware from kit and ones previously taken off in step 1). Take 5/16' x 3" bolt and put in hole on end of axle and install lock washer and nut. **Per diagram D.**
9. Tighten 5/16" bolt with 2-1/2" wrenches.
10. Repeat steps 8 & 9 for second tire.

Diagram A
And
Diagram B

CUT LINE

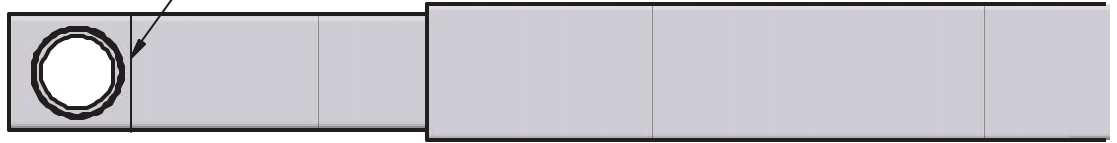

Diagram C

